

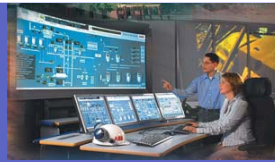

**PQF LV Active Filters:
Bringing energy
savings to you...**

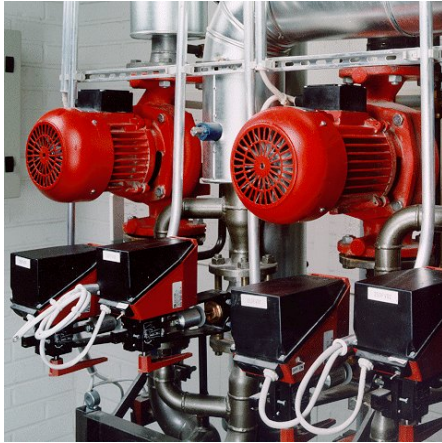

Key elements of poor LV Power Quality



Harmonics



Reactive power

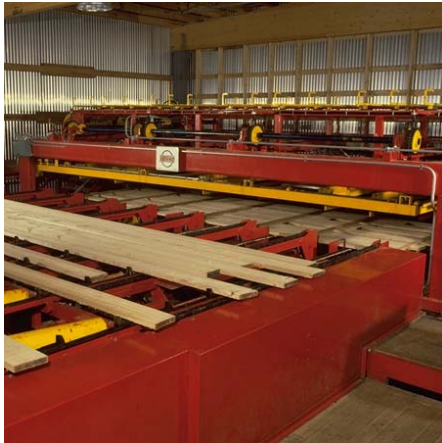

Load imbalance

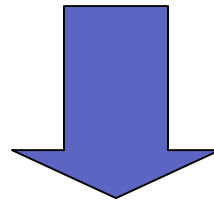

Energy losses and high running costs



Customer inquiry

- Can ABB PQF active filters help to realize energy savings?
- The question becomes more popular with increasing energy prices
- The answer is...

→ **4 field reports...**



Field report 1: Installation on ferries

■ The installation

Power plant: 2 generators

Main load: 2 DC drive propulsion units

Performance without filters:

G1: 660 A, G2: 580 A $\cos \varphi$: 0.76

THDV = 22%, THDI = 25%

Av. consumption: 14000-15000 l/month



■ The inquiry

- Install filters to solve harmonic problems due to propulsion DC drives
- Perform $\cos \varphi$ compensation without overcompensation

Field report 1: Installation on ferries

- Reasons for choosing ABB active filters
 - Compact solution (paramount given the limited space aboard)
 - Excellent filtering performance
 - Possibilities to perform transient-free reactive power compensation up to target $\cos \varphi$
- Customer findings and consequent actions
 - Technical problems resolved
 - With ABB PQF active filters operational, about 10% of fuel savings were reported resulting in drastically reduced running costs
- Further actions of customer and findings
 - Installation of ABB PQF active filters on other ferries of customer
 - 10% of fuel savings have also been confirmed on the other ferries

Customer gain: per ferry about 18000 l fuel per year



Field report 2: Industrial extruder lines

■ Customer

- Runs various extruder lines resulting in THDV of about 11% on LV side
- Extruder lines are DC drive based
- Due to the harmonics in the voltage, voltage wave form had multiple zero crossings which upset the DC drive control causing damage
- Hopes to have reduction of losses in (long) feeding cables and feeding transformers (billing aspect and cable overheating aspect)

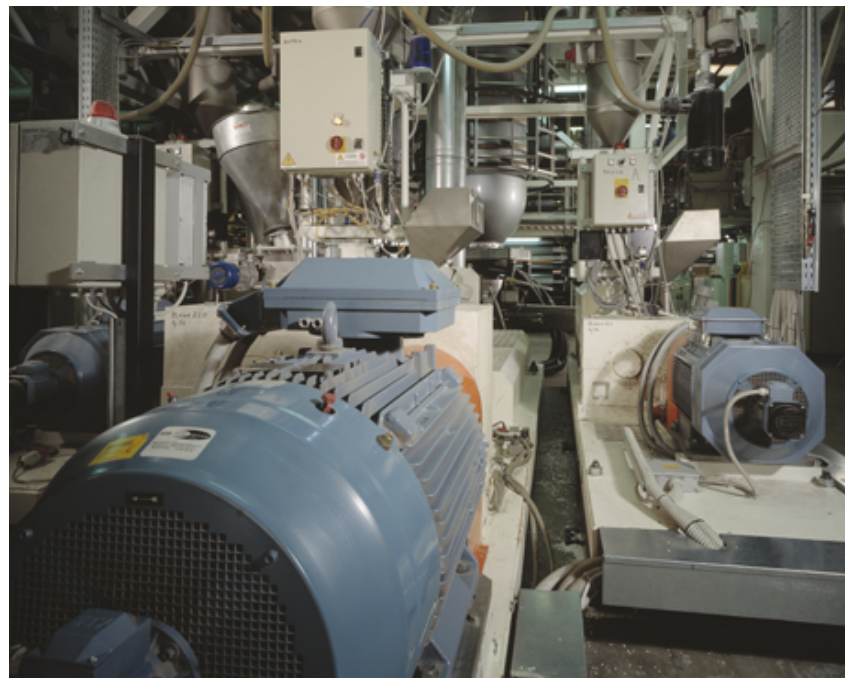

Field report 2: Industrial extruder lines

- Reasons for choosing ABB active filters
 - Only supplier with long term track record for large power active filters
 - ABB in house engineering of the product giving confidence for future support
 - Possibility to set $\cos \varphi$ target value and possibility to assign resources to this task



Field report 2: Industrial extruder lines

- Customer findings and consequent actions
 - Technical problems in production line disappeared
 - $\cos \varphi$ of the installation increased from 0.84 to 0.92 on average
 - In house on-line power consumption monitoring indicated around 10-15% savings of active power which resulted in very short pay back time of installation

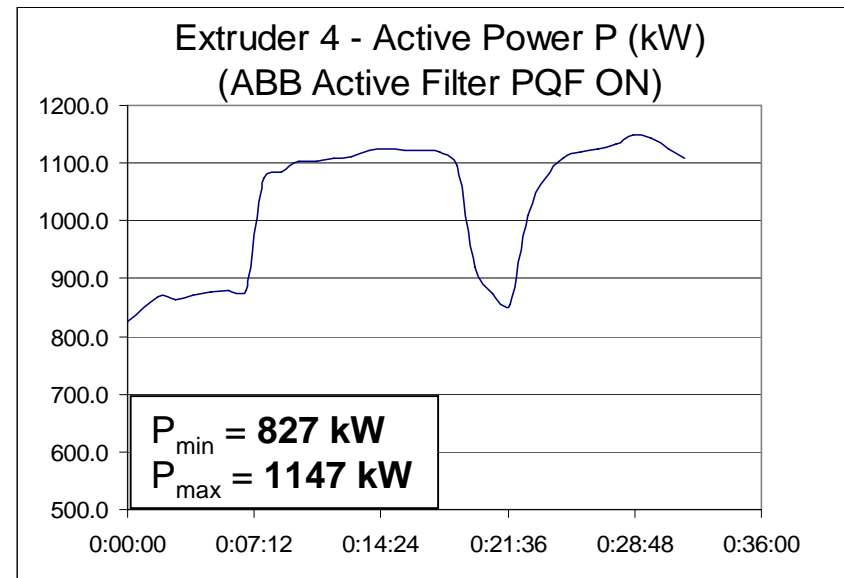
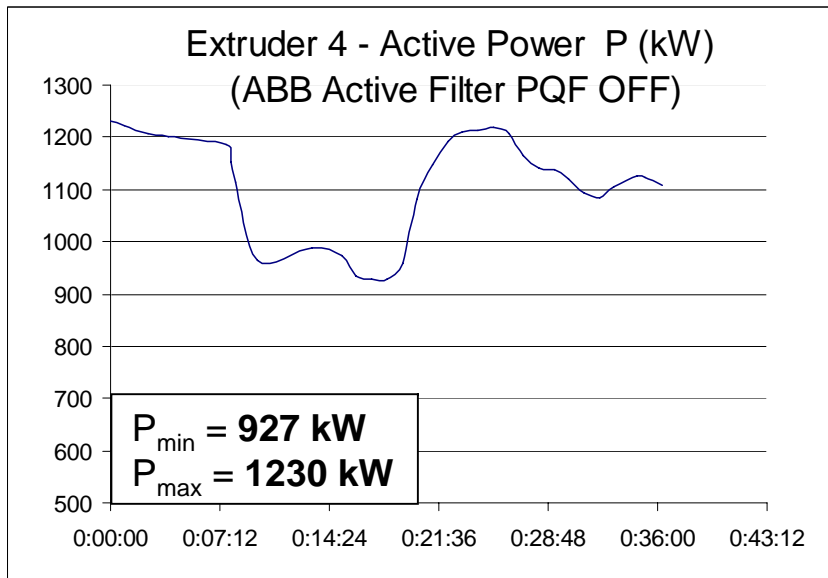

Field report 2: Industrial extruder lines

- ABB verification measurement with high precision measuring equipment indicated that
 - measuring equipment used by the company functions correctly
 - during the verification measurement with and without active filter also around 11% power savings were recorded when filter running
- ABB contacted independent 3rd party European accredited measurement laboratory, 'Labo Lemcko' to re-measure and verify the validity of the measurements made...



Field report 2: Industrial extruder lines

- Independent laboratory confirmed 14.5 % energy savings!

Energy (kWh) vs Time (h)

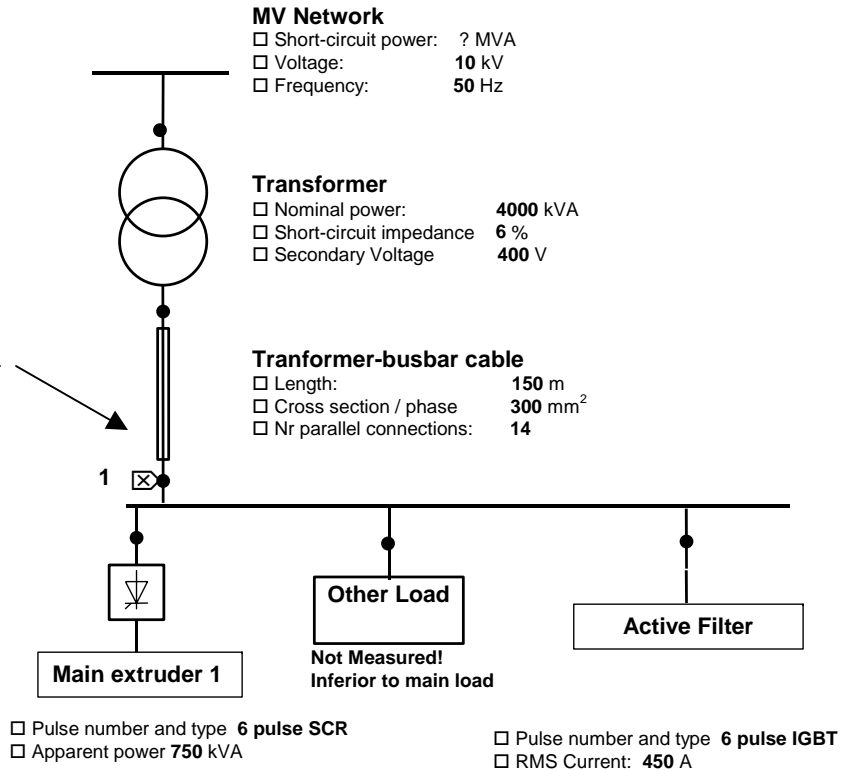
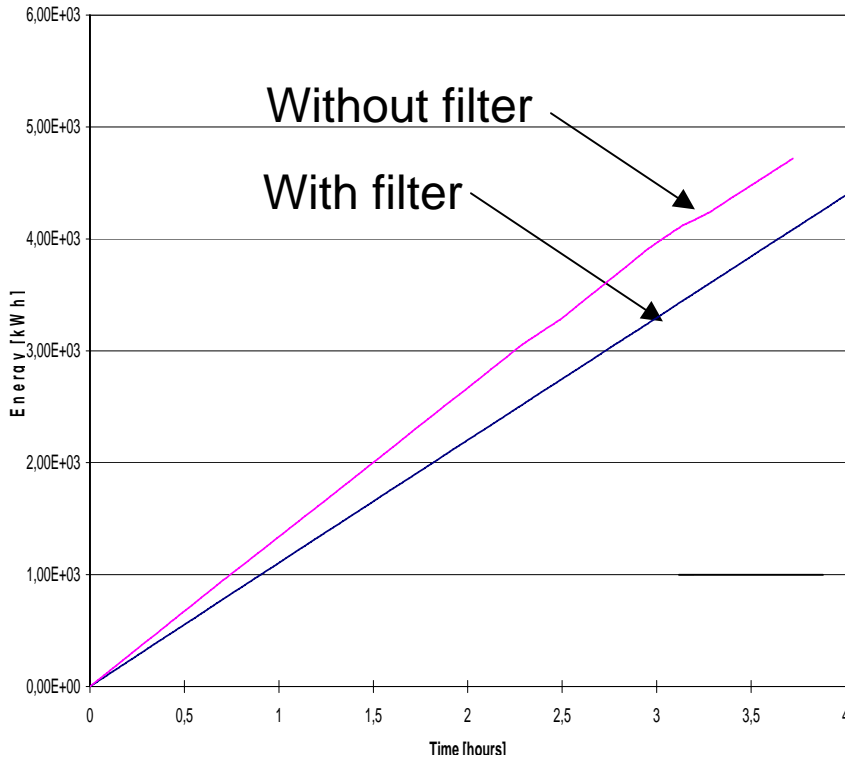

Customer gain: more than 70 kUSD per year



Field report 2: Industrial extruder lines

■ Financial analysis over time

Year	Accumulated energy savings (kUSD)
1	>70
2	>140
3	>210
4	>280
...	...

Note: during the first year, the customer has already profit because the production line down time is reduced.

Pay-back time

Additional profit

Very short pay-back time is realized



Field Report 2: Industrial extruder lines

- Further actions of customer
 - Customer has ordered additional ABB PQF LV Active Filters for other production lines



Field report 3: AC drives – paper industry

■ Customer

- Runs many AC drives and has set up an evaluation program of savings with and without active filter
- Measurements were done over periods of one month with and without active filter (March: active filter not running, April: active filter running)

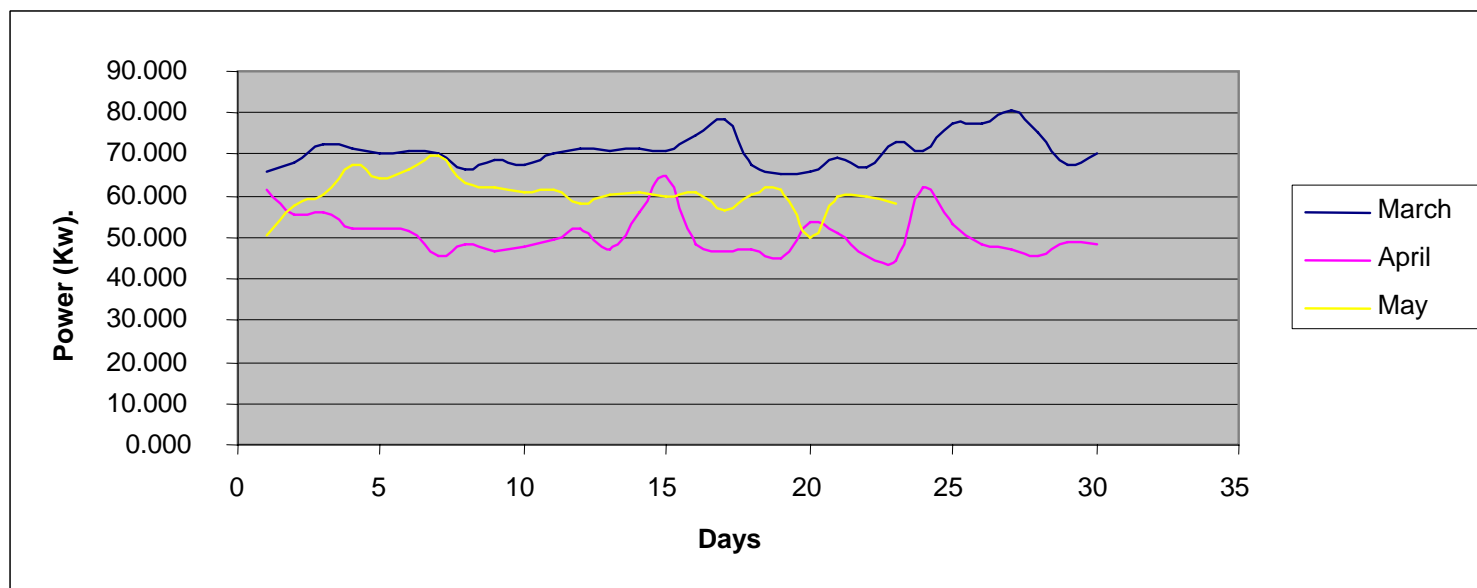

Field report 3: AC drives – paper industry

- Customer findings and consequent actions
 - Customer reports on average 10% savings when active filter is used
 - Customer is at present making inventory of all his harmonic loads and requests ABB to quote for an overall filter solution



Field report 4: stadium flood lights

- Customer
 - Needs to offload supply cables to the flood lights (overheating problem due to cable losses)
 - Needs to ensure that system can run on stand alone generator basis due to international football organization rules
 - Installs active filters to accommodate the above



Field report 4: stadium flood lights

- Customer findings
 - Cable losses are reduced by 33% resulting in acceptable operation
 - Technical problems (generator operation) are resolved
- Consequence
 - Reduction of cable losses has positive impact on energy bill



Large induction machine analysis

- For a 1 MW induction machine a loss evaluation with and without harmonics was made
- Conclusions for the machine considered
 - If supply voltage contains 10% H5 distortion, the losses in the machine (due to n.p.s. current) increase by approx. 10-13%
 - Temperature increase in the machine due to the losses is approx. 10 Kelvin
- Consequences
 - Loss increase in the machine has to be paid for
 - The lifetime of this machine is greatly reduced due to temperature increase



Conclusions

- More and more data emerge indicating that poor Power Quality of the electrical network results in substantially increased electrical losses and consequent down-time and financial loss
- Field reports indicate that ABB PQF LV Active Filters offer an efficient solution to reduce down-time and bring substantial energy savings to customers

PQF LV Active Filters

Bringing energy savings to you!



The ABB logo consists of the letters 'A', 'B', and 'B' in a bold, red, sans-serif font. Each letter is composed of two overlapping shapes, creating a sense of depth and movement. The 'A' is formed by two overlapping 'A' shapes, the first 'B' by two overlapping 'B' shapes, and the second 'B' by two overlapping 'B' shapes.

Power and productivity
for a better world™